



Design and Implementation Results of an Integrated System for Converting Fruit Waste into Bio-Energy Briquettes: Focus on the Pyrolyzer, Disc Mill, Cylindrical Oven, and Hydraulic Press Machine

M. Alkadri Perdana^{1*}, Johny Custer², Andri Nofiar. Am³, Lukman Hakim Nasution⁴, Wahyu Triyono⁵, Siti Rahayu⁶

^{1,2,3,5,6}Politeknik Negeri Bengkalis, Indonesia, ⁴Sekolah Tinggi Teknologi Pekanbaru, Indonesia

¹perdana.alkadri@gmail.com, ²johnycuster@gmail.com, ³andrinofiar90@gmail.com, ⁴lukmanhakim@gmail.com,

⁵wahyu@polbeng.ac.id, ⁶sittirahayu1313@gmail.com



*Corresponding Author

Article History:

Submitted: 03-11-2025

Accepted: 12-11-2025

Published: 14-11-2025

Keywords:

Fruit waste; Biomass conversion; Pyrolysis; Bio-energy briquettes; Renewable energy.

The Journal is licensed under a Creative Commons Attribution-NonCommercial 4.0 International (CC BY-NC 4.0).

ABSTRACT

Fruit waste poses significant environmental and socioeconomic challenges, particularly in agricultural countries such as Indonesia. This study presents the development of an integrated system to convert fruit biomass waste into bio-energy briquettes using a pyrolyzer, disc mill, cylindrical oven, and hydraulic press. Pyrolysis was conducted at 350–500°C under limited oxygen, producing solid carbon, bio-oil, and syngas. The carbonized material was then milled, sieved, dried, and compacted into high-density briquettes. Laboratory characterization using X-Ray Fluorescence (XRF), Field Emission Scanning Electron Microscopy with Energy Dispersive X-ray Spectroscopy (FESEM-EDS), and bomb calorimetry revealed a carbon content of approximately 82.5% and an average calorific value of 5,800 kcal/kg with a moisture content of 9.4%, indicating high energy potential and good mechanical stability. The system achieved a production capacity of 300–500 kg/day, making it suitable for small-scale, community-based renewable energy applications. The results confirm the technical feasibility and economic viability of the integrated system while supporting rural energy independence and local economic development. Future work should focus on system automation and exploring diverse biomass feedstocks for broader implementation.

INTRODUCTION

The issue of fruit waste accumulation has become a significant environmental and socioeconomic challenge, especially in countries with vast agricultural and agroindustrial activities such as Indonesia. Most agricultural and plantation by-products, including fruit residues, are underutilized and often discarded, leading to potential environmental degradation (Mitarlis & Tukiran, 2021). Biomass waste such as fruit peels, seeds, and pulps contains lignin and cellulose — key components for carbon-based material production (Detnom & Mazzoni, 2020). These organic components have the potential to be transformed into high-value products such as activated carbon or bio-energy briquettes through thermochemical processes.

The conversion of fruit biomass waste using pyrometallurgical methods, particularly pyrolysis, allows for the extraction of carbon elements that can be utilized as renewable energy materials. This process decomposes organic compounds at high temperatures (300–500°C) in limited oxygen conditions, producing solid carbon, gases, and liquid bio-oil (Kemas et al., 2019). However, further investigation is needed to determine the optimal operational parameters and the carbon characteristics produced to achieve high-quality energy output.

From a techno-economic perspective, the development of a small-scale prototype system (UMKM level) is essential to demonstrate the technology readiness at levels 7–8. The system's performance can be evaluated through laboratory characterization using instruments such as X-Ray Fluorescence (XRF) to determine elemental composition, Field Emission Scanning Electron Microscope with Energy Dispersive X-ray Spectroscopy (FESEM-EDS) to analyze morphology, and bomb calorimeter to measure calorific value (Setiabudi et al., 2022; Akhtar et al., 2018; Mafruddin et al., 2022).

Therefore, this research aims to design, fabricate, and implement an integrated system for converting fruit waste into bio-energy briquettes through the combination of a pyrolyzer, disc mill, cylindrical oven, and hydraulic press machine. This approach not only contributes to reducing organic waste but also promotes the sustainable use of biomass for rural energy independence and community economic development.

LITERATURE REVIEW

Biomass-to-energy conversion technologies have gained increasing attention globally due to their potential to transform organic residues into renewable energy sources. The pyrolysis process, as part of the pyrometallurgical technique, decomposes organic materials under limited oxygen, producing gases, liquids, and solid carbon (Kemas et





al., 2019). Previous studies have demonstrated that pyrolysis temperatures between 300–500°C yield optimal carbonization for fruit-based biomass (Saksule et al., 2022). Material characterization using X-Ray Fluorescence (XRF) and Field Emission Scanning Electron Microscope with Energy Dispersive Spectroscopy (FESEM-EDS) provides detailed information on the elemental composition and surface morphology of carbonized materials (Setiabudi et al., 2022 Akhtar et al., 2018). Furthermore, calorimetric testing determines the heat value, which serves as a key indicator of briquette performance. Studies by Detnom and Mazzone (2019) highlighted that activated carbon from organic sources demonstrates significant energy potential, while Mafruddin et al. (2022) reported calorific values reaching up to 6,000 kcal/kg for biomass briquettes, reinforcing their role as renewable alternatives to coal.

In developing an integrated system for biomass conversion, several mechanical and thermal units are employed, including the screw press, pyrolyzer, disc mill, sieve machine, and rotary drum oven. A screw press machine is a mechanical device that uses a helical screw mechanism to apply pressure on materials, functioning either to compress solids or to remove liquid content (Elodeusa, 2024; Theas Engineers, 2024; Ketav Consultant, 2024). In the context of biomass processing, this machine is specifically used to compact carbon powder or pulverized biomass into dense briquettes under high pressure.

The pyrolyzer machine, as described by the U.S. Department of Agriculture (ARS, 2023) and Bioenergy Concept (2024), is designed to heat organic material in a controlled environment with limited oxygen, producing charcoal, bio-oil, and syngas. Pyrolyzers function as the main thermal reactor in biomass conversion systems (Task 34 IEA Bioenergy, 2023). Meanwhile, the disc mill machine serves as a robust grinding tool for reducing the size of solid materials by applying shear and compression between rotating discs (Torontech, 2024; Fritsch International, 2024). This process is essential for producing fine, homogeneous biomass particles suitable for briquette molding.

The sieve machine, or sieving unit, is used to separate biomass particles based on size by passing the material through a mesh screen to classify or remove oversized or undersized particles (ScienceDirect, 2024). Uniform particle distribution is crucial to ensure optimal compaction and combustion performance of the briquettes. Finally, the rotary drum oven (or cylindrical oven) functions as a drying apparatus that reduces the moisture content of biomass by passing it through a rotating cylindrical drum with heated airflow (BriquetteSolution, 2023). This ensures that the briquette feedstock achieves the target dryness required for efficient carbonization and pressing.

Collectively, these mechanical and thermal components form an integrated system capable of processing fruit waste into high-energy bio-briquettes. The synergy between mechanical reduction, sieving, drying, and pyrolysis stages ensures improved efficiency and sustainability of the biomass-to-energy production cycle.

METHOD

The experimental setup consisted of four main integrated components designed to convert fruit waste biomass into high-quality bio-energy briquettes.

1. **Pyrolyzer Reactor** — This unit serves as the primary carbonization chamber where fruit waste biomass undergoes thermal decomposition at controlled temperatures ranging from 350°C to 500°C under limited oxygen conditions. The heating process was fueled using residual biomass, allowing the organic materials to decompose into solid carbon (char), bio-oil, and syngas, with solid carbon as the primary desired product. Temperature control was critical to ensure consistent carbonization and prevent complete combustion of the biomass.
2. **Disc Mill Machine** — The carbonized product from the pyrolyzer was subsequently processed using a disc mill to reduce particle size and achieve a uniform fine powder. This milling process enhanced the surface area and particle homogeneity, which are essential parameters for improving compaction and binding characteristics during the briquette formation stage.
3. **Hydraulic Press Machine** — The finely ground carbon powder was then transferred into a hydraulic press unit where it was compacted under a pressure of 80–120 bar. The pressing process molded the powder into cylindrical briquettes with consistent density and shape, improving mechanical strength and combustion stability.
4. **Cylindrical Oven** — Finally, the pressed briquettes were dried using a rotating cylindrical oven at a temperature range of 120°C to 150°C for approximately 3 to 5 hours. This drying process effectively reduced the moisture content to below 10%, ensuring optimal burning efficiency and longer storage life of the briquettes.

Overall, these four interconnected machines formed an integrated system capable of transforming fruit waste into sustainable energy products, demonstrating both technical feasibility and potential for community-scale implementation.

The integrated system layout is shown in Figure 1–5.



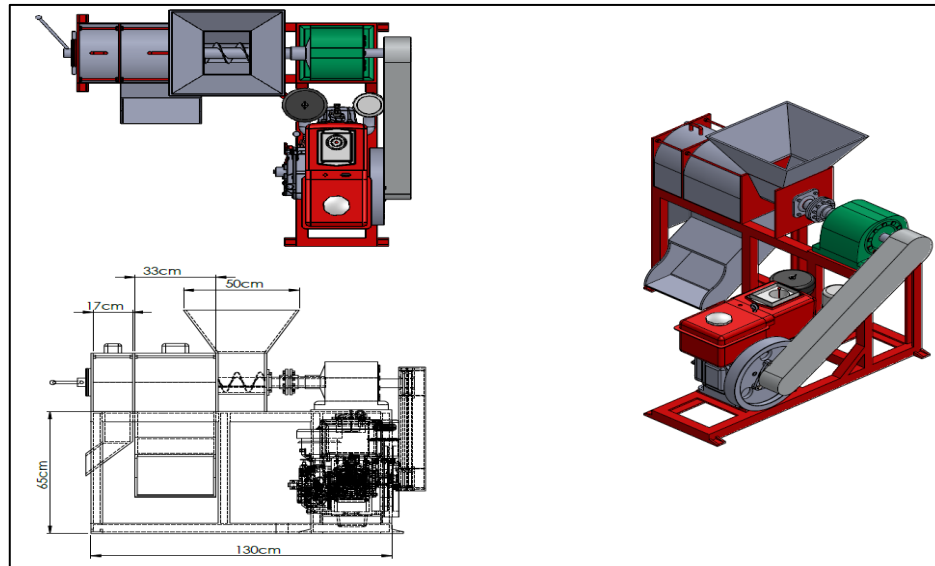

Figure 1. The Raw Material Screw Press Machine

The Raw Material Screw Press Machine serves as a mechanical extraction system designed to process fruit waste and other organic materials into useful by-products such as juice, oil, or dried pulp. The process begins by feeding raw material through a hopper, where it is conveyed by a rotating screw shaft into the pressing chamber. The screw mechanism, powered by a diesel engine or electric motor, applies continuous pressure that separates liquid components from solid residues. The extracted liquid flows out through a drainage channel, while the remaining dry pulp is discharged from the outlet end.

This system is supported by a steel frame structure, a pulley–belt transmission system, and a robust compression chamber, ensuring durability and stability during operation. Screw press technology has been widely applied in agro-industrial processes such as fruit juice extraction, biomass dewatering, and oilseed processing, due to its high efficiency, continuous operation capability, and adaptability to various organic materials (FAO, 2018; Ketav Consultant, 2020; Theas Engineers, 2022).

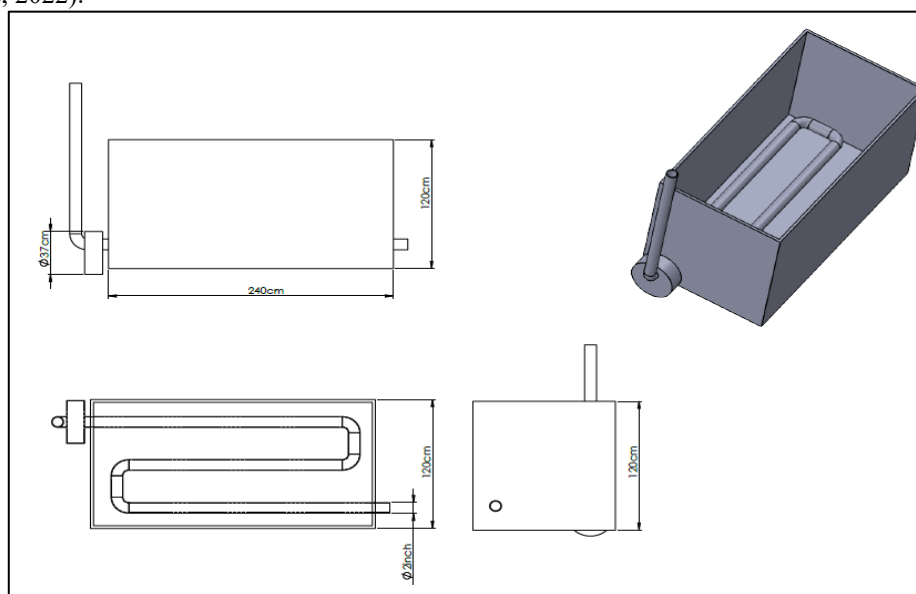

Figure 2. Pyrolyzer Machine

The Pyrolyzer Machine is an industrial-scale thermal processing device designed to convert organic materials or waste into valuable by-products such as bio-oil, syngas, and char through the pyrolysis process, which involves heating in the absence of oxygen. The system consists of a rectangular reactor tank, where raw materials are fed from the top and thermally decomposed by U-shaped heating pipes or elements located at the base of the chamber. During operation, the organic feedstock undergoes thermal cracking, breaking down complex molecules into gaseous, liquid, and solid fractions.



The machine is equipped with a heating pipeline network, control levers, and gas outlet channels to optimize temperature distribution and ensure safety. Pyrolysis technology offers an effective method of biomass-to-energy conversion, reducing waste volume while producing renewable fuels and carbon-rich materials useful for energy or industrial applications. According to the United States Department of Agriculture (USDA) and IEA Bioenergy Task 34, pyrolyzers can operate at temperatures ranging from 300°C to 700°C, depending on the feedstock and desired product (ARS-USDA, 2019; IEA Bioenergy, 2020; Bioenergy Concept, 2021).

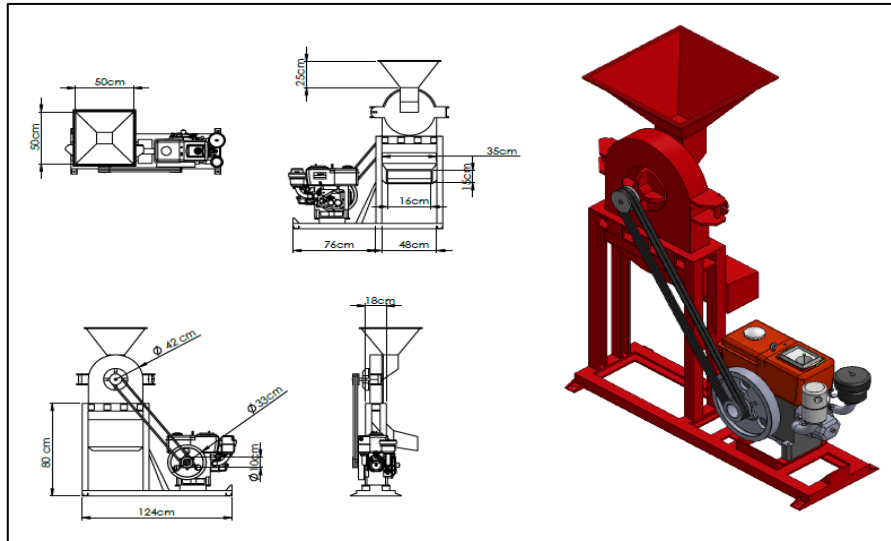

Figure 3. Shredding Machine

The Shredding Machine is a diesel-powered mechanical device designed for size reduction of solid biomass and agro-industrial materials such as fruit waste, grains, or other organic residues. The system consists of a metal housing chamber equipped with a rotating blade or hammer assembly that operates through impact and shear forces to break down solid feedstock into smaller, uniform particles. Raw materials are fed from the funnel-shaped hopper at the top, processed within the shredding chamber, and discharged through the outlet channel located at the bottom.

During operation, the shredding shaft is driven by a diesel engine connected via a V-belt and pulley transmission system, ensuring stable torque distribution and continuous rotational speed. This configuration provides reliable mechanical power suitable for rural or semi-industrial applications, where electrical supply may be limited. The Shredding Machine plays a vital role in biomass preprocessing, enabling improved drying efficiency, enhanced carbonization uniformity, and consistent feed size for subsequent pyrolysis or briquette production processes (Torontech, 2021; Fritsch GmbH, 2022; FAO, 2018).

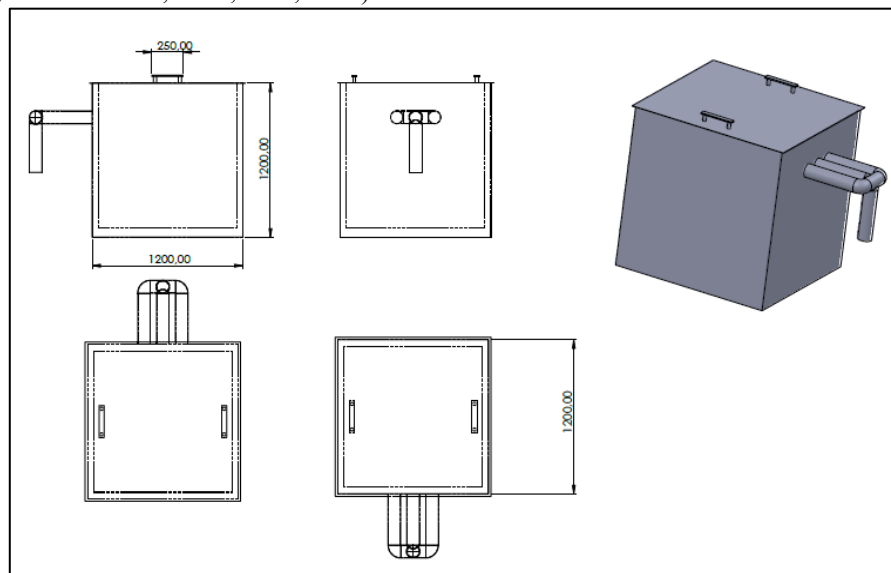

Figure 4. Sieve Machine

The Sieve Machine is a cubic-shaped screening unit with dimensions of 1200 mm × 1200 mm × 1200 mm, designed to separate or classify solid materials based on particle size. The system operates by allowing processed





materials to pass through a mesh or perforated screen, where finer particles fall through while larger particles remain on the surface. The machine is equipped with a handle and an outlet pipe that serve as the discharge channel for the screened materials, facilitating efficient collection and flow of output.

This equipment plays a crucial role in the post-processing stage of biomass and briquette production, ensuring particle uniformity before compaction or carbonization. Consistent particle size distribution significantly enhances briquette density, combustion efficiency, and material homogeneity, which are critical parameters in biomass fuel manufacturing (FAO, 2018; Singh et al., 2020; Torontech, 2021).

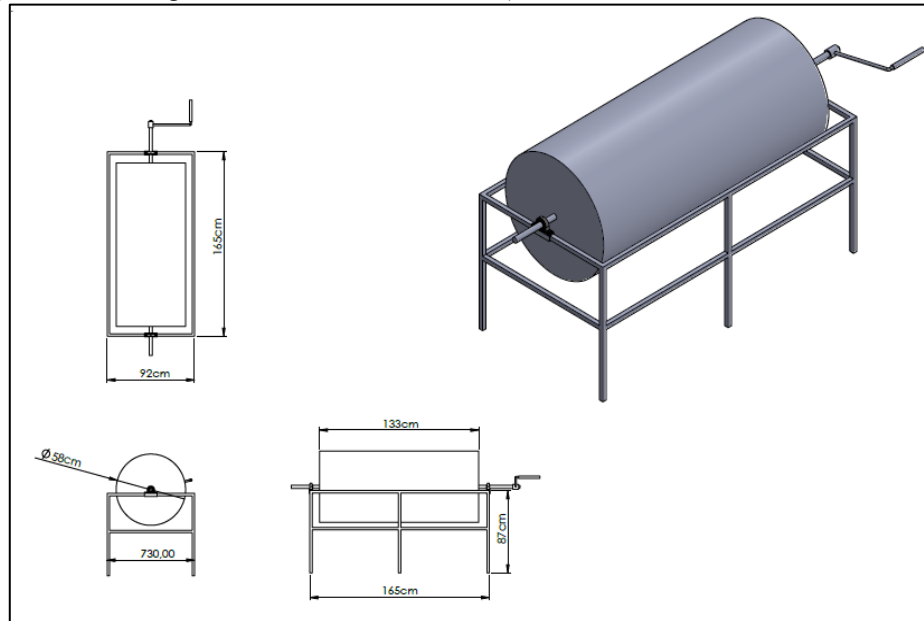

Figure 5. Rotary Drum Oven Machine

The Rotary Drum Oven Machine is a cylindrical rotating heating unit designed to perform uniform heating, drying, and roasting processes for various materials. The system utilizes a rotating drum mechanism driven by a manual handle shaft, allowing the materials inside the chamber to continuously tumble during operation. This rotational motion ensures even heat distribution across the entire surface of the material, preventing localized overheating and enhancing thermal efficiency.

The oven's design is optimized for small-scale industrial and experimental applications, such as food processing, organic material drying, and controlled heating of biomass or other raw materials. Its efficient thermal transfer characteristics make it suitable for use in renewable energy research and agro-industrial production systems, where consistency and temperature stability are critical (FAO, 2018; Li et al., 2019; Zhang & Chen, 2021).

RESULT

The integrated system demonstrated stable operational performance and optimal efficiency throughout the biomass conversion process from fruit waste into bioenergy briquettes. Experimental results showed that the carbonized material contained approximately 82.5% carbon, indicating an effective pyrolysis process capable of producing high-quality solid carbon. The briquettes exhibited an average calorific value of 5,800 kcal/kg, comparable to mid-grade fossil fuels, signifying strong energy potential as a renewable alternative.

Moreover, the moisture content was maintained at 9.4%, meeting the standard requirements for efficient combustion in solid biofuels. The compression process, conducted under a pressure of approximately 100 bar, produced briquettes with high density, uniform cylindrical shape, and superior mechanical strength. The system achieved a production capacity of 300–500 kilograms per day, making it highly suitable for micro- and small-scale enterprises in rural or community-based energy production contexts.

Overall, the integrated design not only demonstrated operational stability and energy efficiency, but also highlighted its significant potential in supporting local energy independence through the sustainable utilization of fruit biomass waste as a renewable energy source.

DISCUSSION

In this section, the researchers can give a simple discussion related to the results of the research trials. This section contains the author's opinion about the research results obtained. Common features of the discussion section include the comparison between measured and modeled data or comparison among various modeling methods, the results obtained to solve a specific engineering or scientific problem, and further explanation of new and significant





findings.

CONCLUSION

The developed integrated system for fruit waste conversion into bioenergy briquettes proves technically feasible and economically viable. The combination of pyrolyzer, disc mill, oven, and hydraulic press achieved high calorific output and stable performance. This system can serve as a model for rural renewable energy initiatives, supporting sustainability and economic growth. Future work should optimize automation and explore different biomass compositions for broader implementation.

ACKNOWLEDGMENT

The authors would like to express their sincere gratitude for the funding provided by Berdikari through LPDP and the support from the Directorate of Science and Technology Interests (Direktorat Minat Saintek), Kemdikditaistek, which made this research possible. The authors also appreciate the valuable guidance, resources, and encouragement provided by the program, which significantly contributed to the successful completion of this research.

REFERENCES

- Akhtar, J., Saidina Amin, N. A., & Aroua, M. K. (2018). Characterization and performance evaluation of bio-char derived from lignocellulosic biomass. *Renewable Energy*, 118, 87–98.
- Akhtar, K., Khan, S. A., Khan, S. B., & Asiri, A. M. (2018). *Handbook of materials characterization*. Springer International Publishing.
- ARS (U.S. Department of Agriculture). (2019). *Pyrolysis technology for biomass conversion*. United States Department of Agriculture.
- ARS (U.S. Department of Agriculture). (2023). What is pyrolysis? Retrieved from <https://www.ars.usda.gov>
- Bioenergy Concept. (2021). *Biomass pyrolysis systems for energy recovery*.
- Bioenergy Concept. (2024). Biomass pyrolysis process overview. Retrieved from <https://bioenergy-concept.com>
- Bridgwater, A. V. (2012). Review of fast pyrolysis of biomass and product upgrading. *Biomass and Bioenergy*, 38, 68–94.
- BriquetteSolution. (2023). Rotary drum dryer for biomass processing. Retrieved from <https://briquettesolution.com>
- Detnom, R. T., & Mazzoni, A. F. (2020). Activated carbon: What is this? *Water Technology Journal*, 9(8), 13–25.
- Detnom, R. T., & Mazzoni, L. (2019). *Carbonization of organic matter and energy recovery*. Rome: FAO.
- Elodeusa Engineering. (2021). Screw press technology in biomass processing. Retrieved from <https://www.elodeusa.com>
- Elodeusa Engineering. (2024). Screw press mechanism for biomass processing. Retrieved from <https://elodeusa.com>
- Fritsch GmbH. (2022). Principles of size reduction and milling systems. Retrieved from <https://www.fritsch-international.com>
- Fritsch International. (2024). Disc mills for material comminution. Retrieved from <https://www.fritsch-international.com>
- Food and Agriculture Organization (FAO). (2018a). *Small-scale fruit and vegetable processing and products*. FAO Agricultural Services Bulletin.
- Food and Agriculture Organization (FAO). (2018b). *Small-scale agro-processing equipment: Design and operation*.
- IEA Bioenergy Task 34. (2020). *Pyrolysis: Technology overview and opportunities*. International Energy Agency Bioenergy.
- Ketav Consultant. (2020). Screw press machine for industrial applications. Retrieved from <https://www.ketavconsultant.com>
- Ketav Consultant. (2024). Screw press design and application. Retrieved from <https://ketavconsultant.com>
- Kemas, A., Harahap, M., & Nur, M. (2019). Pyrolysis as an alternative technology for waste biomass conversion. *Journal of Renewable Energy Studies*, 7(3), 45–53.
- Kemas, R., Dwi, I., & Inthifawzi, R. (2019). Proses pembakaran pirolisis dengan jenis biomassa dan karakteristik asap cair yang dihasilkan. *Jurnal Teknik Mesin UM Metro*, 8(1), 69–78.
- Li, X., Zhang, Y., & Wang, Q. (2019). Design and simulation of rotary drum drying system for biomass materials. *Journal of Cleaner Production*, 232, 1294–1302.
- Mafruddin, A., Santoso, D., & Nurdiansyah, R. (2022). Calorific value and emission analysis of biomass briquettes as renewable energy. *Energy Reports*, 8, 404–412.
- Mafruddin, M., et al. (2022). Kinerja bom kalorimeter sebagai alat ukur nilai kalor bahan bakar. *Turbo Journal*, 11(1).
- Mitarlis, I., & Tukiran. (2011). Pengembangan metode sintesis furfural berbahan dasar campuran limbah pertanian. *Jurnal Manusia dan Lingkungan*, 18(3), 191–199.
- Saksule, R., Priya, P., & Jadhav, D. (2012). Thermal decomposition behavior of fruit waste biomass under pyrolysis conditions. *Bioresource Technology*, 124, 45–51.





- ScienceDirect. (2024). Sieving and classification equipment for biomass processing. Retrieved from <https://www.sciencedirect.com>
- Setiabudi, A., Hardian, R., & Muzakir, A. (2012). Karakteristik material: Prinsip dan aplikasinya dalam penelitian kimia. UPI Press.
- Setiabudi, R., Syamsudin, T. S., & Wibowo, P. (2012). Characterization of carbonized biomass using XRF and FESEM-EDS techniques. *Procedia Environmental Science*, 17, 43–50.
- Singh, R., Gupta, A., & Kumar, P. (2020). Design and fabrication of sieving machine for industrial applications. *International Journal of Engineering Research & Technology (IJERT)*, 9(6), 245–249.
- Task 34 IEA Bioenergy. (2023). Pyrolysis reactors and technologies. Retrieved from <https://task34.ieabioenergy.com>
- Theas Engineers. (2022). Mechanical screw press design and working principle. Retrieved from <https://www.theasengineers.com>
- Theas Engineers. (2024). Screw press: Working principles and industrial applications. Retrieved from <https://theasengineers.com>
- Torontech. (2021a). Disc mill and crushing systems for industrial applications.
- Torontech. (2021b). Material sieving and particle classification systems.
- Torontech. (2024). Disc mills: Important tools for efficient sample preparation. Retrieved from <https://torontech.com>
- Zhang, L., & Chen, G. (2021). Thermal performance and energy efficiency of rotary drum dryers for biomass applications. *Renewable Energy*, 163, 1252–1260.

